

CLOUDS

Acoustic insulation and acoustic conditioning made of bio soluble fiber glass sheets with a facing in non-woven white fiber, bonded with a thermosetting resin, uniform texture, is designed to be used in ceiling tiles and in acoustic control systems.

Applications and Solutions:

- Dividing walls
- Low ceilings
- Auditoriums
- Cinemas
- Recording studios
- Technical rooms
- Boilers

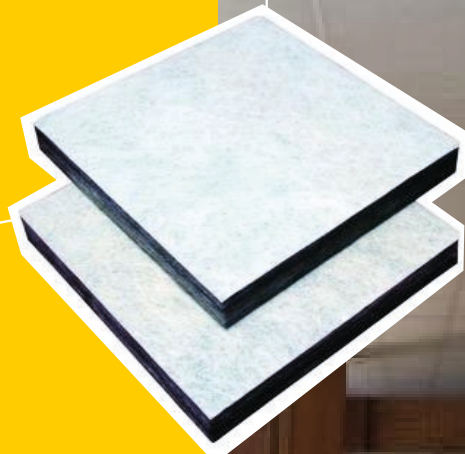



END USE CHARACTERISTICS AND LIMITATIONS

The product is designed to be installed as ceiling tile in T grid exposed. Product dimensions, length and wide, are always smaller than dimensions of the grid base to allow proper fit. T grid is available in hot dipped galvanized steel strip of 24 mm (15/16in) width. This product offers an excellent performance in acoustic conditioning; it is dimensionally stable and will not shrink or warp, making it highly durable.

This product is not recommended, and its properties are not warrantable if it is used in any of the following areas:

- Bath, shower or pool covers areas adjacent or near steam pipes or chimneys, kitchens, or laundry areas that require to be washed with disinfectant substances, hydrocarbons or water vapor.

- Areas where the material may be subject to physical abuse, sport areas or other areas where it may be beaten with an object.
- Areas where the material could be exposed to chemical vapors in laboratories, industrial production facilities, etc.
- Areas where the product may receive humidity effect by condensation.

Product certified by LAPEM (Testing Laboratory Equipment and Materials, Mexico)

PRODUCT SPECIFICATION

Product	Length	Wide	Thickness (2)	Net weight + 10%
ISOVER	m	mm	mm	kg / m ² (g/ft ²)
Clouds 4' x 2' x 1' (1)	1219 ± 5mm	610 ± 3mm	254 ± 5mm	1.92 (178.35)
Clouds 4' x 2' x 2' (1)	1219 ± 5mm	610 ± 3mm	254 ± 5mm	2.43 (225.91)
Clouds 48' x 96' x 1'	2438 ± 5mm	1219 ± 3mm	203 ± 4mm	3.20 (297.24)
Clouds 48' x 96' x 2'	2438 ± 5mm	1219 ± 3mm	203 ± 2mm	2.56 (237.80)

Squareness: Angles at 90°, maximum 3mm deviation.

(1) The presentation in 4'x2' considers dimensions of installation in suspension systems in profiles in "T". When profiles are used in 19 mm (3/4 wide), specified tolerances in length and wide must be considered.

(2) Measurement method, stack height: Average of 4 measurements taken on the centers from the stack.

Properties	Standard	Clouds (1 in)	Clouds (1 in)
Thermal performance (Thermal resistance)	ASTM C518	4.3 hr.ft ² .°F /BTU Typical value a 75°F Mean Temp (0.77 m ² .°C / W at 24°C Mean temp)	
Acoustic Performance (Noise Reduction Coefficient)	ASTM 423 A Mounting	NRC 0.7	NRC 1.00
Water Vapor Sorption	ASTM C1104/C1104M	<3% weight-120°F (49°C), 95% R.H.	
Surface Burning Characteristics	ASTM E84 / UL723	Flame Spread Index < 25 Smoke Developed Index < 50	
Corrosiveness	ASTM C665 / ASTM C795	Meets requirements	
Rigidity	C1101 / C1101M	Classifies as rigid	
Linear Shrinkage	ASTM C356	< 2% Change in Length	
Fungi resistance	ASTM C1338	Meets requirements	
Odor Emission	ASTM C1304	Meets requirements	
DBE Content	Oregon State	FREE, Meets requirements	

NOISE REDUCTION COEFFICIENT

PRODUCT TYPE AND THICKNESS (A Mounting)	DENSITY		OCTAVE BAND CENTER FRECUENCIES, Hz							TERMAL RESISTANCE (2) (gr.ft ² .°F /BTU) R100(m ² .°C/W)
	pcf	kh/m ³	125	250	500	1000	2000	4000	NRC (1)	
1" Mat Faced	3.0	48	0.06	0.25	0.62	0.91	0.99	0.98	0.70	4.30 (77.59)
2" Mat Faced	3.0	48	0.18	0.71	1.12	1.12	1.03	1.02	1.00	8.60 (155.19)

(1)NRC: Noise reduction coefficient. ASTM C423 Standard Test Method for Sound Absorption Coefficients by the Reverberation Room Method. The NRC values should be used as a quick screening tool to compare different construction assemblies. (A Mounting: Material placed against a solid backing such as a block wall)

(2) Thermal transmittance U=1/R (BTU/hr. ft². °F -W/m².°C)

VISUAL STANDARD

Characteristic	Acceptance guide
Color	The surface color is grayish white by contrast with the fiberglass sheet (color from black grey to black), for this reason there may be variations within a batch and between batches.
Surface and Facing Appearance	<p>Generally, surface is flat, without protuberances. Given that the facing is with open pore, ensure that the installation does not generate pressure differences to keep the visual aspect of the sheet insulation; otherwise it could act as a circulating air filter.</p> <p>The acceptance guide of visual standard applies only for the surface of the sheet. The following aspects are considered when cause damaging to the aspect of the product:</p> <ul style="list-style-type: none"> - Surface wrinkled, torn or stained. Wrinkles with depth no greater than 0.5 mm and with a maximum length of 5 cm, are considered product characteristics or air bags between the sheet and the film. - Different colors visible to eye in the same installation, after of being ensured that is not being used mixing with products installed before, and discarding variations mentioned before - Buckling with respect to the profile, greater than 4mm. - Defects in the weave, which compromise the overall appearance of the installation.
Handling	The product does not break under normal conditions; proper handling must be assured at transportation and warehousing.

PACKAGING

Product	Units /package	área/package (m ²)	Net weight +/-10% kg/package
CLOUDS 4' x 2' x 1" (1)	10	7.43	9.1
CLOUDS 4' x 2' x 2" (1)	5	3.72	9.1
CLOUDS 48" x 96" x 1"	8	23.78	29.2
CLOUDS 48" x 96" x 2"	4	11.89	29.2

Package: Polyethylene shrink-package, extremes closed and autoadhesive label.
 GROSS WEIGHT (kg/package) = NET WEIGHT (kg/package) + 2 kg aprox.

Contenido de Reciclado

- (1) PI Post Industrial Recycled Content: Collected from Manufacturers or industry.
 (2) PC Recycled Content Post-Consumer: Collected from end uses.

Product	Total recycled content	Post-industrial recycled content PI (1)	Post-consumer recycled content PC (2)
CLOUDS 1 in	63.2%	63.2%	0%
CLOUDS 2 in	66.30%	66.30%	0%

INSTALLATION RECOMMENDATIONS

1. Planning the installation of ceiling tile.
2. Install the Wall angle.
3. Locate and hang the suspension of main TEE.
4. Install the main Tee.
5. Install the Cross Tee and fit edges.
6. Install the ceiling panels.

Consult with the technical area to installation recommendations.

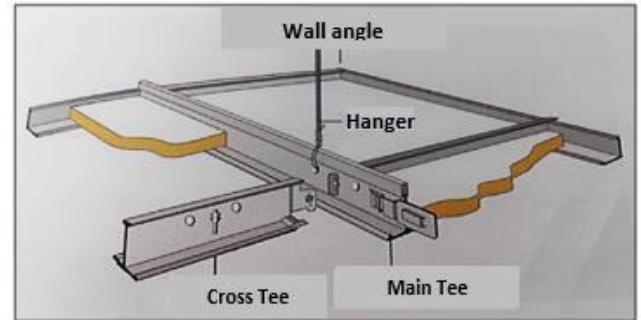

CFE Una empresa de clase mundial
LAPEM
 LABORATORIO DE PRUEBAS DE EQUIPOS Y MATERIALES

FIBERGLASS COLOMBIA S.A PROVEEDOR AUTORIZADO

El Laboratorio de Pruebas Equipos y Materiales (LAPEM) es una organización de la Comisión Federal de Electricidad que tiene como objetivo atender las necesidades del sector eléctrico nacional e internacional, proporcionando estudios de ingeniería especializada, pruebas de laboratorio y campo a equipos y materiales.

Fiberglass Colombia S.A - Colombia
Planta Mosquera
Mineral Glass Wool AA1

Certificado No.385 Lana Mineral de vidrio biosoluble FGC. Nota Q de la regulación EC 1272/2008 conforme al Parlamento y al Concejo Europeo.

European Certification Board for Mineral Wool Products

<p>N° CO11/4442</p> <p>Sistema de Gestión de la Calidad para la producción y venta de membranas impermeabilizantes modificadas (mantos, con o sin recubrimiento autoprotector) y emulsiones asfálticas, Cielo rasos en fibra de vidrio con acabado decorativo. Láminas y rollos flexibles en fibra de vidrio para la fabricación y recubrimiento interno y externo de conductos para transporte de aire acondicionado. Aislamientos térmicos y acústicos rígidos, flexibles y preformados.</p>	 <p>Norma - ISO 9001:2015</p> <p>Producto fabricado bajo un sistema de administración de calidad certificado de conformidad con ISO 9001.</p>	<p>Los valores reportados son típicos de pruebas llevadas a cabo en muestras tomadas de producción estándar y podrían ser actualizados sin previo aviso.</p> <p>El usuario es responsable de determinar si el producto está recomendado para una superficie en particular y si se adapta a la aplicación requerida por este. El usuario debe hacer las pruebas y ensayos de aplicación del producto que requiera para tal efecto.</p> <p><i>Copia no controlada. La información contenida en este documento puede ser actualizada sin previo aviso.</i></p>
---	---	---